

IEEE 1588 PTP Solutions

Get synchronized!

When it comes to device or system synchronization in the nano second range, trust on our versatile and reliable IEEE 1588 solutions

IEEE 1588 PTP is a packet-based time-synchronization mechanism typically used in Ethernet networks. It synchronizes the clocks of different devices with the most accurate clock on the network – usually a precise, grandmaster clock, such as one using a GPS time signal. The master-slave relationship is configured by a “best master clock” algorithm. The configuration adapts automatically as devices are added to or removed from the network.

Depending on the type of network and the hardware used, IEEE 1588 PTP can achieve time-synchronization accuracies of under 100 nanoseconds. In complex networks with partially unknown packet delays, such as in typical telecom applications, IXXAT offers a special filter that helps to improve synchronization accuracy.

IXXAT and IEEE 1588

As the market leader in IEEE 1588 PTP Protocol Software, IXXAT offers a highly developed, application-proven package with a wide range of functions. IXXAT's collaboration with major semiconductor manufacturers, and active participation within the relevant standards committees, insures continuous product improvements according to the latest technical standards. This means you can trust the IXXAT IEEE 1588 PTP solution as a solid basis for your current and future development.

Products

IEEE 1588 Protocol Software

The IXXAT IEEE 1588 PTP Protocol Software enables quick and simple development of IEEE 1588-2008 compliant devices. The software is modular, making it easy to adapt it exactly to application requirements. The interfaces with the target platform, for example to access the UDP/IP socket, are grouped in a separate adaptation layer for which the only requirement is a multicast capable UDP/IP stack. This simplifies porting to target systems and ensures quick integration.

IXXAT supports a wide range of hardware and OS platforms such as:

- Freescale QorIQ P2020
- Freescale i.MX28
- STMicroelectronics STM32F107/207

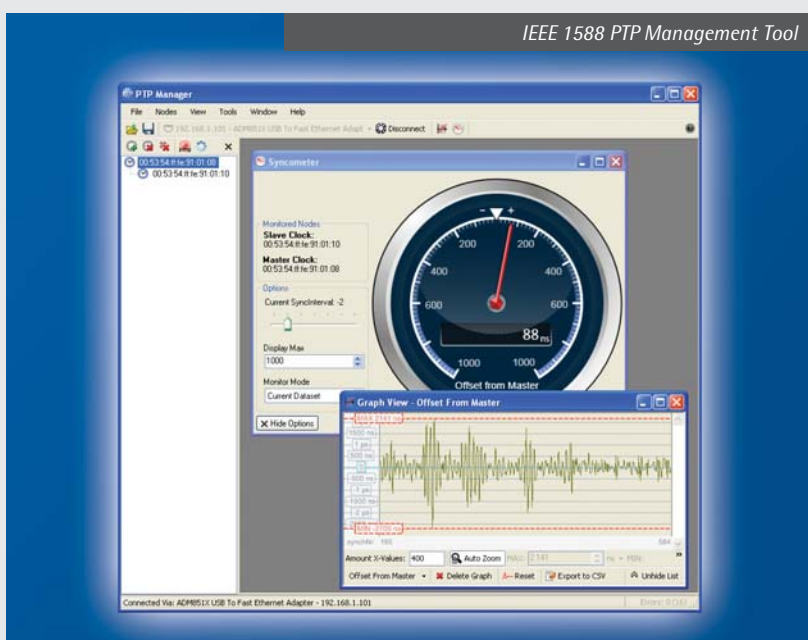



- Altera FPGAs with NIOS Soft CPU (time-stamping unit and RTC available separately)
- Generic Linux with software time-stamping
- Windows

You can download evaluation binaries from the IXXAT homepage. Source code versions for evaluation are available on request.

IXXAT IEEE 1588 IP-Core

As an addition to the IEEE 1588 PTP Protocol Software, the IEEE 1588 IP-Core adds accurate time-stamping capability, a trigger unit and an IEEE 1588 compliant real-time clock to FPGAs. By processing the synchronization packets between the PHY and the MAC, you can achieve clock synchronization in the

two digit nanosecond range. The scalability of ports and timer/trigger units enables the IXXAT IEEE 1588 IP-Core to be used as a component in complex devices with several network interfaces.

IXXAT IEEE 1588 PTP Management Tool

The IXXAT IEEE 1588 PTP Management Tool uses the management interface of PTP clocks to work with all IEEE 1588-2008 compliant PTP clocks. The GUI describes the current system hierarchy and a time graph of the synchronization behavior. Single nodes can be selected for reading and modifying the properties or the entire network can be monitored and configured, making the IXXAT IEEE 1588 PTP Management Tool an ideal complement to the IXXAT IEEE 1588 Protocol Software for developing and commissioning PTP clocks.

Services and Support

Technology Seminars

One day training on IEEE 1588 PTP technology, mechanisms, and applications. You can combine this seminar with the Code Introduction Training (see below).

Code Introduction Training

One day training on the source code running on a target platform. This training explains in detail the interfaces, processes, and data flows within the IEEE 1588 stack and describes how to adapt it to various platforms.

Development Services

- Requirement analysis and specification
- Adaptation and implementation support and services
- Hardware development
- Troubleshooting and on-site support

Maintenance and Support Contract

- Free updates and bug fixes
- Participation in the developments of the stack
- Technical support by phone or e-mail

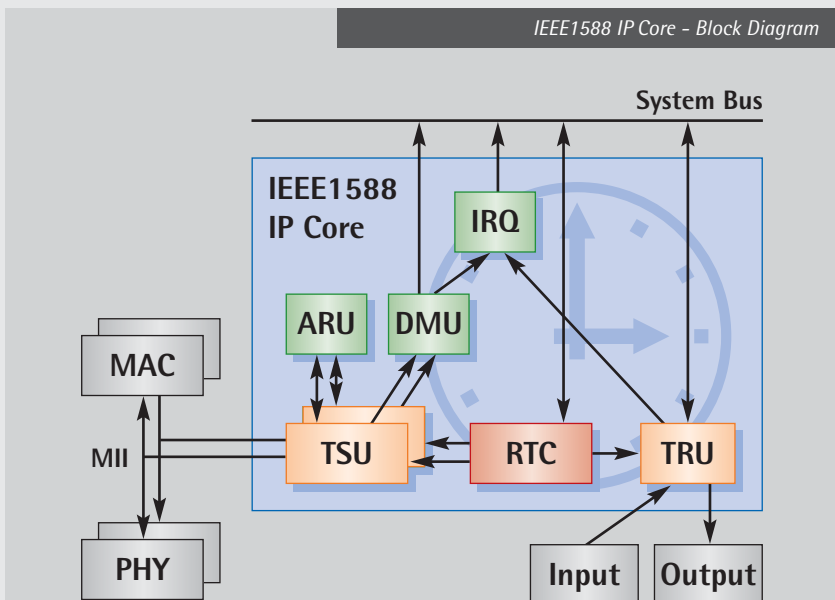

Success Stories

IXXAT IEEE 1588 PTP

Solutions are Already Used...

- For Geological measurements with high numbers of widely distributed sensors
- At telecommunications companies making mobile backhaul solutions, GPS grand-master clocks or test devices
- By day-trading software companies for synchronizing servers
- In Intelligent Electronic Devices (IEDs) for electric power sub-station distribution
- By industrial networking companies
- To synchronize satellites
- For the LXI conformance test, which is based on the IXXAT stack and IXXAT's external clock hardware

Customer Benefits

Technical Benefits

- Modular and scalable solutions (easy to adapt to specific requirements)
- Ease of porting to target systems
- Optimized use of memory and resources for embedded applications
- Short synchronization time at system start, after changes in the network as well as in response to disturbances

Minimizing the Cost and Development Risk

- Complete software suite from one supplier

- Professional support
- Comprehensive services before, during and after development
 - Technology and product training
 - Consulting and development services
 - Onsite troubleshooting
- Strong partners:
 - Altera
 - AMCC
 - Freescale
 - Intel
 - STMicroelectronics
 - Symmetricom
- Adaptation to the main platforms with IEEE 1588 support
- Widespread customer base

Overview of Products and Features

Products	IEEE 1588 PTP Protocol Software	IEEE 1588 PTP IP-Core Module for FPGAs	IEEE 1588 PTP Management Tool
Description	Software package for easy and rapid development of IEEE 1588 devices	Real-time clock and timer/trigger unit for Altera FPGAs (Solutions for Xilinx FPGAs on request)	Tool for monitoring and configuring IEEE 1588 networks
Included functions	Ordinary/boundary clock Best Master Clock algorithm Management protocol/interface Multicast support One-step/two-step support Peer-to-peer/end-to-end delay mechanism UDP/IPv4 multicast support Simple API for the application connection Works with or without OS Annex J – default PTP profiles Optimized filter algorithms for complex and high traffic networks Interface to Symmetricom Clock Servo Easy adaptation to the target hardware, TCP/IP stack and operating system Extensions Ext. 1: UDP/IPv6 Ext. 2: IEEE 802.3 (layer 2) support Ext. 3: Unicast – Master/slave capability Ext. 4: Transparent Clock – Unicast over TC, End-to-end TC, Peer-to-peer TC Ext. 5: Telecom features	Setting/adjusting the real-time clock by software Time-stamping of external input signals by the trigger unit Triggering external output signals based on configurable timers MII interface for detecting incoming/ outgoing sync messages Standard address bus / data bus interface Buffer for time-stamp and additional information for message assignment, including the possibility of interrupt generation Variable external clock frequency Generating external PPS signals to check the clock synchronization. Requires IEEE 1588 PTP protocol software on an internal or external CPU	Automatic detection of PTP clocks in the network Supports multicast and unicast Supports data sets of the ordinary, boundary and transparent clocks Display of the master-slave relationship of PTP clocks in a tree hierarchy Display of the PTP clock data sets Adjustment of the clock configuration using SET and COMMAND messages Graphic output of "One Way Delay", "Offset from Master" and "Observed Drift" Adjustable PTP domain